



INSTALLATION INSTRUCTIONS IMPORTANT SAFEGUARDS

CONSTANT
POWER

FOR MODELS: ACE-X10-1555CP, ACE-X10T-1555CP, ACE-X16-1555CP,
ACE-X16T-1555CP, ACE-X16-1555WCP

Emergency LED driver

When using electrical equipment, basic safety precautions should always be followed, including the following:

READ AND FOLLOW ALL SAFETY INSTRUCTIONS:

1. To prevent electrical shock, do not engage battery connector until installation is complete and AC power is supplied to the unit.
2. To reduce the risk of electrical shock, disconnect both normal and emergency power sources and disconnect the battery connector before servicing.
3. This is a sealed unit. Components are not replaceable. Replace the entire unit when necessary.
4. Installation and servicing should be performed by qualified personnel only.
5. This unit must be grounded. See the wiring diagrams for details.
6. An unswitched AC power source is required (120 – 277 Vac, 50/60 Hz).
7. The emergency LED driver must be fed from the same branch circuit as the AC LED driver.
8. The emergency LED driver should be mounted in locations and heights where it will not readily be subjected to tampering by unauthorized personnel.
9. This product is for use with an emergency LED lighting load (LED load) and supplies P Watts of power (see table below), with a voltage of 15 – 55 Vdc in emergency mode for a minimum of 90 minutes, in compliance with NFPA-101 and NEC 700.12.
10. The ACE-X___CP Series Emergency LED driver is intended to be mounted in an enclosed compartment or wireway within a luminaire and is suitable for factory or field installation.

Power Supplied to emergency LED lighting load (LED Load)	ACE-X___CP Model
10 Watts	ACE-X10-1555CP, ACE-X10T-1555CP
16 Watts	ACE-X16-1555CP, ACE-X16T-1555CP, ACE-X16-1555WCP

11. This product is suitable for use in damp locations where the ambient temperature is in the range of 0 °C minimum (-20 °C for “T” models) to 55 °C maximum. This product is also suitable for use in sealed and gasketed fixtures. This product is not suitable for heated air outlets, wet locations, or hazardous locations. The maximum allowable case temperature at the Tc point is 66 °C. See Illustration 1 for the location of the Tc point.
12. The use of accessory equipment not recommended by the manufacturer may cause an unsafe condition, void the warranty, or result in non-compliance with regulations.
13. Do not mount near gas or electric heaters. Do not use this product for other than its intended use.
14. Install in accordance with the National Electrical Code and local regulations.

SAVE THESE INSTRUCTIONS



Emergency LED driver
for use with suitable
LED luminaires



Certified in CA Title 20
Appliance Efficiency
Database – Battery Charger



Complies to FCC
commercial limits



This product contains a
rechargeable Lithium-ion battery.
The battery must be recycled or
disposed of properly.



3401 Avenue D, Arlington, TX 76011 • 800-375-6355 • aceleds.com

Data is based upon tests performed by AC Electronics in a controlled environment and representative performance. Actual performance can vary depending on operating conditions. Specifications are subject to change without notice. All specifications are nominal unless otherwise noted.

CAUTION:

DO NOT ENGAGE BATTERY CONNECTOR UNTIL INSTALLATION IS COMPLETE AND AC POWER IS SUPPLIED TO THE UNIT.

NOTE: Make sure the necessary branch circuit wiring is available. An unswitched source of power is required. The emergency LED driver must be fed from the same branch circuit as the AC LED driver.

This product is suitable for field installation with compatible LED luminaires and LED loads. The following items need to be checked to determine if the LED luminaire is suitable for field installation.

- A. Ensure that the rated power of the LED load is greater than or equal to the power output of this emergency LED driver so that the LED load is not overpowered in emergency mode.
- B. Verify that the forward voltage (Vf) of the luminaire's LED array (LED load) is within the limits of this emergency LED driver's output operating range.
- C. Ensure that the output current of the AC LED driver does not exceed 5 A (8 A for 20W models).
- D. Ensure that there will be sufficient emergency egress lighting illumination levels per national, state, and local codes. Use the following guidelines.
 - 1.) Determine the efficacy (lm/W) of the LED load. This information is typically given by the luminaire manufacturer in lumens per Watt (lm/W or LPW). It can also be obtained by direct measurement or published in a 3rd party database such as UL, Design Lights Consortium (www.designlights.org), or other qualifying means.
 - 2.) The light output of the LED load in lumens can be calculated by multiplying the output power (W) by the efficacy of the LED load (lm/W). This will provide a conservative estimate and serve well as a beginning point for the emergency lighting design. Use the following equation and example as a guide:

$$\text{Lumens in emergency mode (lm)} = (\text{emergency LED driver output power (W)}) \times (\text{LED load efficacy (lm/W)})$$

Example: Given: Emergency LED driver output power = 10 W
LED load efficacy = 100 lm/W

Then: **Lumens in emergency mode = 10 x 100 = 1000 lm**

Note: The above serves only as an example, actual results will depend on the specific data for the specific application.

- 3.) Once the light output (lm) is determined, use industry standard lighting design tools to estimate the illumination levels for the emergency egress path.

Note: This product is compatible with most LED fixtures and LED loads that meet criteria A, B, and C above. However, interoperability and compatibility cannot be guaranteed. Compatibility and interoperability testing for the end-use application is recommended. Please contact the factory should there be questions.

Note: After installation, it is necessary that the emergency egress lighting illumination levels be measured to ensure compliance with national, state, and local codes

Installation of this emergency LED driver may vary from one luminaire type to another; however, the following steps generally apply:

Step 1.) Installing the emergency LED driver

- Ensure that AC power is disconnected from the LED luminaire.
- Mount the emergency LED driver by the mounting tabs using the supplied hardware. See Illustration 1.

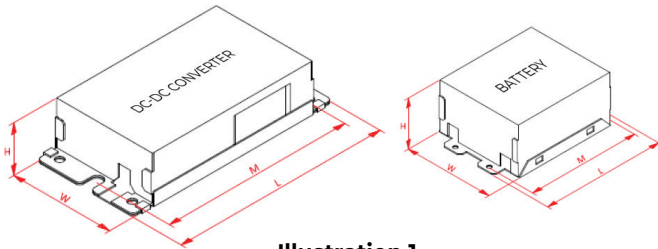

Illustration 1.
Unit dimensions, location of Tc, and mounting tabs

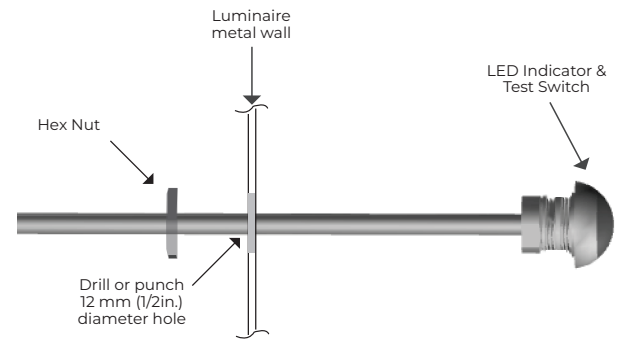

Illustration 2.
LED Indicator & Test Switch

Wiring the Emergency LED driver

Step 2.) Wiring diagram selection: Select the appropriate wiring diagram.

Note: All wiring practices and connections should comply with the National Electrical Code and local safety guidelines and regulations.

Step 3.) Wiring the AC power input section: The emergency LED driver has 3 AC power input wires: one black, one white, and one black/yellow. Connect the black/yellow wire to the AC input unswitched line. Next, if an external wall switch is used, and if it is desired to allow the emergency LED driver to control the timing of applied power upon transition from emergency-mode to normal-mode, then connect the black wire from the emergency LED driver to one side of the external wall switch, then connect the other side of the external wall switch to the black AC input wire of the AC LED Driver. If an external wall switch is used, and if it is not desired to allow the emergency LED driver to control the timing of applied power upon transition from emergency-mode to normal-mode, then connect the wall switch directly to the black AC input wire of the AC LED Driver and simply cap off the black wire from the emergency LED driver. Next, connect the white wire (neutral) from the emergency LED driver and the white wire (neutral) from the AC LED Driver to the AC input neutral.

Step 4.) Wiring the output section: The emergency LED driver has 4 output wires: one red (+), one blue (-), one white/red (+), and one white/blue (-). Connect the red (+) wire from the emergency LED driver output to the output positive (+) wire of the AC LED Driver. Connect the blue (-) wire from the emergency LED driver output to the output negative (-) wire of the AC LED Driver. Connect the white/red (+) wire from the emergency LED driver output to the positive terminal of the LED load. Connect the white/blue (-) from the emergency LED driver output to the negative terminal of the LED load.

Step 5.) Installing the LED Indicator & test switch Mount the supplied LED Indicator & Test Switch in a location on the luminaire or mount it to a wall plate where it is visible and accessible by maintenance personnel. The LED Indicator & Test Switch mounts through a 12 mm (1/2 in.) diameter hole which may need to be made in the luminaire. See Illustration 2.

Wire the LED Indicator & Test Switch per wiring diagrams provided in these instructions. After installing the LED Indicator & Test Switch, mark with the "PUSH TO TEST" and "CHARGING LED INDICATOR" labels.

Step 6.) Make final wiring connections and apply AC power: For "T" models connect the Heating Element Connector. After the wiring connections and installation are complete, supply AC power to the luminaire and engage the battery connector. With AC power connected to both the AC LED driver and the emergency LED driver, and with the battery connector engaged, the LED indicator should illuminate indicating that the battery is charging correctly.

Step 7.) Final Step, test the emergency LED driver: After the emergency LED driver has charged for at least one hour, a short-term discharge test may be conducted by pressing and holding the test switch. The emergency LED driver should be allowed to charge for 24 hours before conducting a 90-minute discharge test.

OPERATION

Normal Mode: With the normal AC supply of power present, the AC LED driver operates as normal, and the emergency LED driver is in battery charging mode, as well as power loss monitoring mode.

Emergency Mode: In the event of a normal AC power failure, the emergency LED driver switches to emergency mode and operates the fixture's LED array or module for 90 minutes, or until normal power returns, whichever occurs first. When normal power returns, the emergency LED driver returns to normal mode.

MAINTENANCE

No routine maintenance is necessary to keep the emergency LED driver functional. However, periodic testing of emergency lighting equipment is required per NFPA-101.

1. While in normal mode, visually inspect that the LED Indicator is illuminated. If the LED Indicator is illuminating continuously, then that is an indication the battery is charging correctly.
2. A monthly test (with a minimum of 3 weeks and a maximum of 5 weeks between intervals) should be conducted for not less than 30 seconds. The emergency LED driver should properly operate the LED load for the full duration of this test.
3. An annual test should be conducted for a full 90 minutes. The emergency LED driver should properly operate the LED load for the full duration of this test.

SHOULD SERVICING BE REQUIRED AS INDICATED BY THESE TESTS, PLEASE REFER TO QUALIFIED PERSONNEL!

WIRING DIAGRAM

The emergency LED driver must be fed from the same branch circuit as the AC driver.

Models: ACE-X10-1555CP, ACE-X10T-1555CP, ACE-X16-1555CP, ACE-X16T-1555CP, ACE-X16-1555WCP

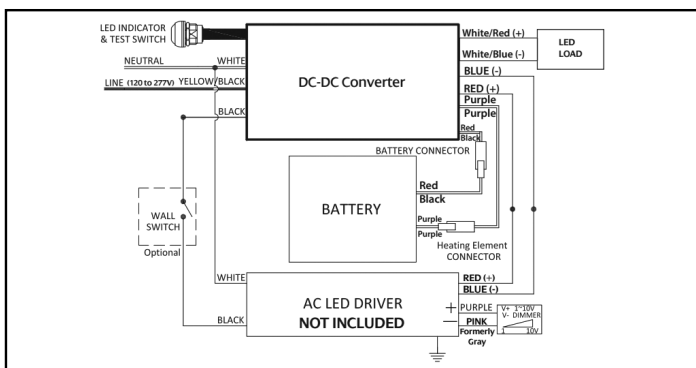

Illustration 3.
Use if an external switched line is not available.

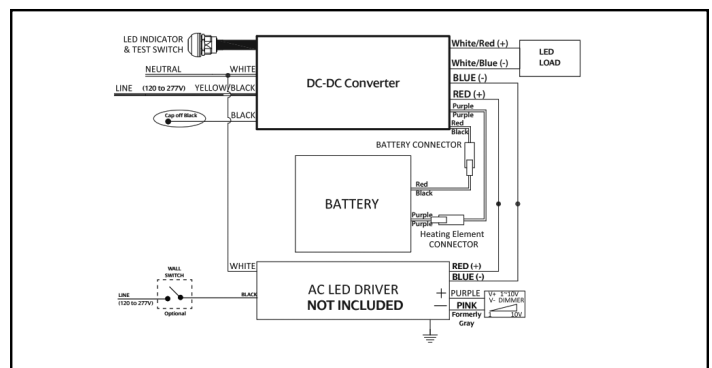

Illustration 4.
Use if an external switched line is available.

NOTE: Only the "T" models include the Heating Element CONNECTOR